



**ACh/Ch Kit**

December, 1999

**MF-9053**

**INSTRUCTION MANUAL**

---

Acetylcholine/Choline  
Assay Kit

---

Bioanalytical  
Systems, Inc  
2701 Kent Avenue  
West Lafayette  
Indiana 47906

MANUFACTURER'S NOTE

The BAS logo is a registered trademark of Bioanalytical Systems, Inc.

*ProClin*<sup>®</sup> is a registered trademark of Rohm & Haas Co.

*Teflon*<sup>®</sup> is a registered trademark of DuPont

*Trizma*<sup>®</sup> is a registered trademark of Sigma Chemical Co.

*UniNut*<sup>®</sup> is a registered trademark of Bioanalytical Systems, Inc.

Copyright December 1999

No portion of this manual may be reproduced without express, written permission of Bioanalytical Systems, Inc.

ALL RIGHTS RESERVED

Bioanalytical Systems, Inc.

2701 Kent Avenue

West Lafayette, IN USA 47906-1382

Phone: (765) 463-4527

Fax: (765) 497-1102

**IMPORTANT!**

This Instruction Manual is used with both the Conventional Cartridge Column version of the BAS Acetylcholine-Choline Assay Kit (BAS part number MF-8910) and with the UniJet Microbore version (BAS part number MF-8908).

If you are setting up the UniJet Microbore Kit, proceed to Section 2 and also refer to the supplemental information provided in the “Guide for Use: BAS UniJet Microbore Columns”, which is included with your Microbore Columns. That document contains directions on plumbing your UniJet columns to your chromatograph.

The general principle of the acetylcholine and choline assay, using either conventional or microbore columns, is described in Section 1. A platinum electrode is supplied with the conventional kit. In addition, a brief description of the peroxidase electrode can be found in Appendix I, page 32. Use of this enzyme electrode can lead to lower detection limits for ACh. This electrode is not included in either version of the kit.

**Table of Contents**

Section 1. ACh/Ch Assay Principle And Conventional Bore Cartridge Column Kit.....	1
1.1 Introduction .....	1
Figure 1-1. Detection .....	1
1.2 Kit Principle.....	2
Figure 1-2. Column hardware.....	2
1.3 Advantages of this Kit.....	3
1.4 Inventory of the Conventional Kit.....	4
1.5 Optional Accessories.....	4
1.6 Start Up Procedures .....	5
1.7 Chromatographic Conditions .....	6
Figure 1-3. ACh and Ch.....	9
1.8 Fine Tuning the Separation.....	10
Figure 1-4. [Tris] .....	11
Figure 1-5. [Na <sup>+</sup> ].....	11
1.9 Application to Microdialysates .....	12
Figure 1-6. BAS “Rodent Residence” awake system .....	12
Figure 1-7. Microdialysates .....	13
Figure 1-8. Tissue .....	14
1.10 Effect of Inhibitors, Trapping Column.....	15
Figure 1-9. Neostigmine .....	15
Figure 1-10. Physostigmine experiment.....	16
Figure 1-11. Reproducibility .....	17
1.11 Determining Only Acetylcholine or Choline.....	18
Figure 1-12. Chromatographic Flow Sequence .....	18
Figure 1-13. ACh only .....	19
Figure 1-14. Arrangement of columns.....	19
1.12 Notes and Cautions .....	20
Figure 1-15. Elution of acetylthiocholine (AcTCh).....	22
Figure 1-16. Dialysate from rat caudate nucleus .....	23

Section 2. UniJet Microbore ACh/Ch Kit.....	25
2.1 Inventory of Microbore ACh/Ch Kit.....	25
2.2 Optional Accessories .....	25
2.3 Installation of the ACh/Ch Microbore Column and IMERs.....	25
Figure 2-1. Components.....	26
2.4 Chromatographic System Conditions .....	26
Figure 2-2. UniJet microbore analytical column and IMER.....	27
Figure 2-3. Rat striatum microdialysate.....	27
Figure 2-4. Internal standard.....	28
2.5 Use of a Guard Column.....	29
Figure 2-5. Connecting a guard column.....	29
Figure 2-6. Comparison of performance.....	29
2.6 Determining Only Acetylcholine or Choline.....	30
Figure 2-7. Microbore Chromatographic Flow Sequence .....	30
2.7 Care of the Analytical Column and IMERs.....	31
Appendix I. Introduction to the Peroxidase Electrode.....	32
References .....	32
Ordering Information.....	32

## Section 1. ACh/Ch Assay Principle And Conventional Bore Cartridge Column Kit

### 1.1 Introduction

The use of enzymes as selective reagents in liquid chromatography was first reported in the early 1970s, and several useful reviews now exist in the analytical literature. For the neurochemicals acetylcholine (ACh) and choline (Ch), enzymes provide an essential means for their detection. The compounds are neither electroactive nor UV-absorbing under reasonable conditions. However, via enzyme catalyzed reactions (Fig. 1-1) both compounds are converted to hydrogen peroxide, a compound which may be either oxidized or reduced.

**Figure 1-1.** Conversion scheme for ACh and Ch to H<sub>2</sub>O<sub>2</sub>.

**ACh**

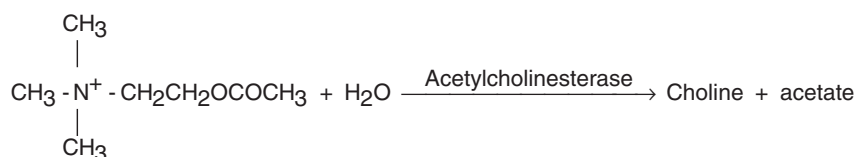

**Ch**

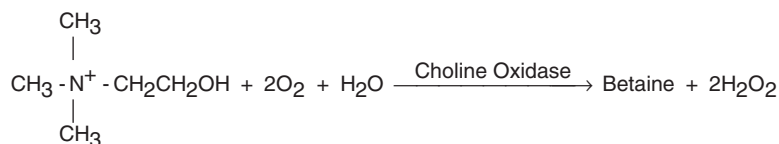

For ACh and Ch, the initial report by Potter, Meek, and Neff of the National Institutes of Mental Health utilized the post-column addition of soluble enzymes, acetylcholinesterase (AChE) and choline oxidase (ChOx), to the effluent from the analytical column. The conversions to H<sub>2</sub>O<sub>2</sub> took only a few minutes, and the product was detected at +0.5 V vs. Ag/AgCl using the selective platinum electrode in an amperometric thin-layer cell.

Later on, Meek and Eva improved the assay by quasi-immobilizing AChE and ChOx onto a weak anion exchanger. This was easily accomplished using low ionic strength mobile phases. The assay was simpler, required less equipment, and conserved precious enzyme.

Concurrently, several *covalent* methods of enzyme attachment have been reported. These have exhibited good catalytic lifetimes and similar ease of use. Moreover, covalent attachment permits more flexibility in the separation conditions, particularly with regard to pH and ionic strength.

The BAS assay utilizes AChE and ChOx covalently attached to a packing material. The result is an immobilized enzyme reactor (IMER). This manual provides the techniques for the installation and use of these IMERs, as well as the analytical column which is used to separate the analytes of interest: ACh and Ch.

## 1.2 Kit Principle

An analytical column and a post column IMER are coupled in series in the liquid chromatography system (Figure 1-2).

**Figure 1-2.** Column hardware for kit.

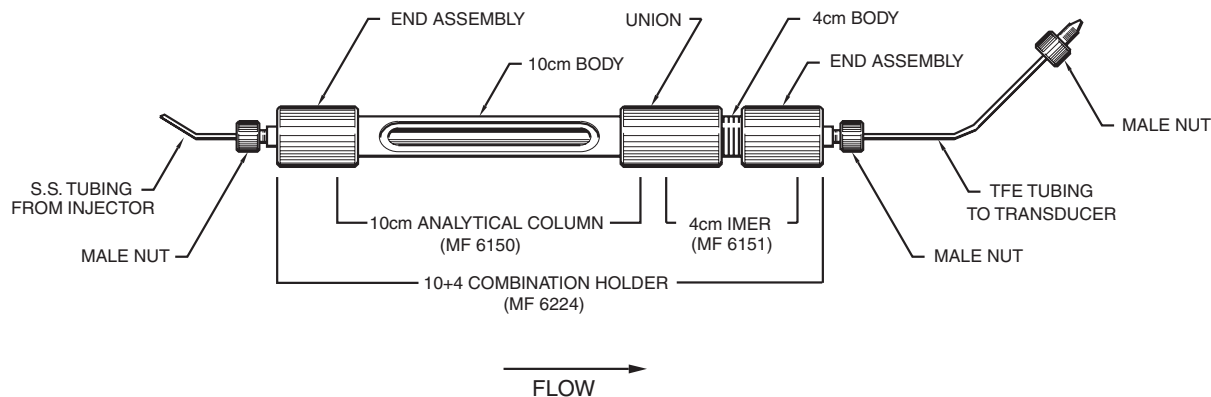

First in line, the polymeric analytical column separates ACh and Ch as a pair well-resolved from unretained peaks. Retention is mostly regulated by ionic strength. The second column, a ready-to-use IMER, is coupled to the outlet of the analytical column. The IMER should be stored with mobile phase at 4°C prior to, or between use.

Amperometric detection is used because the hydrogen peroxide is easily oxidized at a Pt electrode held at +0.5 V vs. Ag/AgCl. While H<sub>2</sub>O<sub>2</sub> can also be detected on carbon electrodes, the kinetics of electron transfer is slow, and the overall selectivity of the method suffers.

### 1.3 Advantages of this Kit

- Both the enzyme and analytical columns are made from polymer backbones rather than silica. The polymer packings are rugged at pH 8-9, without any deterioration or need for a saturator column.
- The separation that you will use is not based on ion-pairing equilibria. You can begin to use the columns immediately, since the loading step is eliminated.
- ACh elutes before Ch, which allows conservation of mass sensitivity. Detection limits are better by one order of magnitude.
- Peak symmetry is excellent. Both ACh and Ch elute with minimal tailing. All reverse phase ion pair systems exhibit measurable tailing, which in turn confounds accurate peak integration.
- The AChE and ChOx are covalently immobilized. This results in a more rugged enzyme reactor.
- The system has been applied to the analysis of microdialysates with and without concurrent administration of an esterase inhibitor.

**1.4 Inventory of the Conventional Kit**

<b>Qty</b>	<b>BAS p/n</b>	<b>Description</b>
1	CF-1042	Choline chloride standard
1	CF-1043	Acetylcholine chloride standard
1	MF-1012	Dual platinum working electrode
1	MF-6151	Acetylcholine/Choline IMER
1	MF-6150	Acetylcholine analytical column
1	MF-6224	Cartridge Column holder hardware (10 + 4 cm) + fittings
1	MR-4013	Inlet tube (stainless steel)
1	MR-5000	Outlet tube (plastic)
1	MF-9053	Instruction Manual for ACh/Ch Assay Kit
1	MF-1046	TG-2M Teflon <sup>®</sup> Thin-Layer gaskets for platinum electrode
1	MR-4000	Fingertight fitting
1	CF-2150	1% ProClin reagent
1	MR-4409	PEEK nut and ferrule
1	MR-4029	PEEK backpressure tubing (see #11, page 24)

**1.5 Optional Accessories**

**IMERS:**

- MF-6149 Choline oxidase IMER
- MF-6153 Choline oxidase/Catalase IMER

To add one of these reactors to your system (as a pre-analytical-column reactor) you will also need to order:

- 1 ea. MF-6217 3 cm cartridge body
- 1 ea. MF-6010 guard column union

**Physostigmine Trapping:**

- MF-6262 physostigmine trapping column

Requires:

- 1 ea. MF-6211 guard end assembly
- 1 ea. MF-6010 guard column union

**Wired Enzyme Electrode Kit: (see Appendix I)**



## 1.6 Start Up Procedures

1. Flush the LC system as described in the next section. This step will passivate all metallic surfaces and kill any resident bacteria. This step is **mandatory**.

*Note: LC systems previously used with acetate, citrate, or phosphate mobile phase may be contaminated with bacteria. Bacteria produce catalase, a very efficient (enzyme) scavenger of the hydrogen peroxide you wish to detect! To prevent future contamination, the addition of a bactericide (ProClin) to the mobile phase is recommended (see 1.7, page 6).*

2. Install the analytical column, IMER, and the Pt electrode. The system is then equilibrated with mobile phase. Instructions for mobile phase preparation are on page 6.
3. Make standard solutions (see page 8). Inject a test mixture.
4. Fine tune the separation. Variations in mobile phase ionic strength are used to provide optimal elution patterns.

### Flush Out the LC System

1. Make mobile phase (see page 6) and the following three solutions:
  - a. *H<sub>2</sub>O*. Filter 2 L of LC grade, deionized H<sub>2</sub>O through a 0.2 µm filter. 15-18 megohm-cm service is recommended.
  - b. *Nitric acid solution*. Add 100 mL of concentrated HNO<sub>3</sub> to 200 mL of H<sub>2</sub>O. BE CAREFUL! Observe proper safety precautions. Use protective gear over face, arms, hands, etc. to avoid injury.
  - c. *Acetonitrile/H<sub>2</sub>O solution*. Add 100 mL LC-grade acetonitrile to 900 mL LC-grade H<sub>2</sub>O. Filter through 0.2 µm membrane.
2. Disconnect the column inlet tube at the old column, if present, and divert all flow to a waste receptacle.
3. To remove any previous mobile phase, especially buffer, pump through 50 mL of H<sub>2</sub>O.
4. Pump through 50 mL of the nitric acid solution to passivate metal surfaces and kill bacteria. Flush both paths through the injection valve (LOAD and INJECT positions).
5. Repeat step 4, but use 50-100 mL H<sub>2</sub>O. Keep pumping until the pH is 3 or greater. Test with pH paper.
6. Flush the system with 100 mL of the acetonitrile/H<sub>2</sub>O solution. Change the waste receptacle, do not mix nitric acid with acetonitrile.
7. Flush the system with 50 - 100 mL of fresh mobile phase.

## 1.7 Chromatographic Conditions

1. BAS now recommends two recipes for our standard bore cartridge column (kit MF-8910 or analytical column MF-6150). The Tris/NaClO<sub>4</sub> "Primary" mobile should be tried first, as it is more gentle on pump seals and is better buffered against pH changes.  
*Note: This primary mobile phase should not be used with BAS Microbore UniJet ACh/Ch columns (kit MF-8908 or analytical column MF-8904).*

### Primary Mobile Phase

*Not for Microbore UniJets*

- To each 900 mL of LC-grade water, add: 6.06 g (0.05 moles) Trizma<sup>®</sup> base (Sigma), 7.02 g (0.05 moles) NaClO<sub>4</sub>·H<sub>2</sub>O (Fisher), 5.0 mL 1% ProClin Reagent (BAS CF-2150)\*.
- Calibrate your pH meter using pH 7 and pH 10 buffer standards. Adjust the mobile phase pH to 8.50 ± 0.05 with HCl or HClO<sub>4</sub>.
- Dilute to 1.0 L and filter through a 0.2 µm membrane filter.
- Adjust the retention of ACh and Ch by varying only the NaClO<sub>4</sub> concentration. The lower the concentration of NaClO<sub>4</sub>, the longer the retention times of ACh and Ch, and the wider the spacing between the two analytes.
- Expiration date is one week after production.

### Alternate Mobile Phase

*For Standard bore or microbore ACh columns*

- To each 900 mL LC-grade water, add: 3.40 mL of 85% H<sub>3</sub>PO<sub>4</sub> (50 mmole).
- Add 5.0 mL of 1% ProClin Reagent (BAS CF-2150)\*.
- Calibrate your pH meter using pH 7 and pH 10 buffer standards. Adjust the pH to 8.50 ± 0.05 with sodium hydroxide pellets and dilute (10%-20%) NaOH solution in water.
- Dilute to 1.0 L and filter through a 0.2 µm membrane filter.
- ACh and Ch retention varies as the total concentration of the buffer. The higher the concentration, the shorter the retention time.
- Expiration date is one week after production.

*\*Note: 1% ProClin is a skin sensitizer; avoid skin contact. Wash with water immediately to prevent skin irritation. Further technical information is included on page 23 and on the Material Safety Data Sheet included with this kit.*

*Note: ProClin retards bacterial growth. The mobile phase should be made fresh every week. Designate an expiration date on the label in order to keep track of batches.*

2. Flush out the system with the mobile phase. If you are using mobile phase more than 7 days old, perform all steps in "Flush Out the LC System" on page 5 before flushing with new mobile phase. To be sure all traces of acid are gone after flushing, test the pH of the effluent with pH paper. Value should be in the 8-9 range.
3. Couple the analytical column to the IMER using the union. Although flow through both columns is not directional, it is good practice to maintain the same direction once it is established. Connect the analytical column inlet to the injection valve with the steel tube provided. See Figure 1-2.

*Note: the knurled cartridge end couplings should only be finger-tightened. Use the nuts and ferrules supplied with the cartridge holders to attach the tubes to the end couplings.*

4. Set the flowrate to 1.0 mL/min and flush out the columns with mobile phase.
5. Attach the detector to the enzyme reactor with the plastic tubing and plastic fitting provided.
6. Install the working (Pt) and reference electrodes on the detector. See detector manual for details.
7. Set the parameters to:
  - range or gain = +500 nA f.s.
  - filter = 0.1 Hz, 2 sec, or 5 sec, depending on model
  - electrode = platinum
  - potential = +500 mV vs. Ag/AgCl
  - recorder = 1 V full scale
8. Turn on the detector cell. The offset will initially surge offscale and then begin to subside.
9. Proceed to and complete the next section (making Standard Solutions). The offset should now be below 20 nA. If not, assess the cause by referring to Notes and Cautions on page 20. Turn the range (gain) to 100 nA f.s. Inject 20  $\mu$ L of the ACh/Ch Test Mixture by overloading the loop of the injector, and compare your results to Figure 1-3.

Adjustments, if necessary, may be made in the mobile phase composition after referring to the next section.

## Standard Solutions

Acetylcholine is hydrolyzed under strongly basic or acidic conditions. Bacterial growth is also a problem. Standards which are refrigerated continuously at 4°C will keep for at least 2 weeks if made up in an acidic buffer containing ProClin. Without a preservative, choline is particularly susceptible to bacterial degradation. In one study, after 10 weeks, choline was typically 75% of its original concentration and acetylcholine was unchanged.

### *Standards Diluent*

Pipette 3.0 mL glacial acetic acid into approximately 950 mL of deionized water. Adjust the pH to 5-5.5 with dilute NaOH. Add 5 mL of the 1% ProClin reagent. Dilute to 1.0 L.

*Note: 1% ProClin solution is a skin sensitizer; avoid skin contact.*

### *ACh Stock Standard (2.00 mM)*

Carefully weigh 36.3 mg acetylcholine chloride and dissolve into 100.0 mL of Standard Diluent.

*Note: Acetylcholine and choline are extremely hygroscopic. They will sorb up moisture in the air so readily that the observed mass will drift upward steadily. Let the solids come to room temperature before opening the bottles. Keep opened solid standards in sealed wide-mouthed bottles which contain a bottom layer of dessicant. Store solids in the freezer.*

### *ACh Working Standard (20.0 µM)*

Dilute 1.00 mL of ACh Stock Standard to 100.0 mL final volume with Standard Diluent.

### *Ch Stock Standard (2.00 mM)*

Carefully weigh 27.9 mg choline chloride and dissolve into 100.0 mL of Standard Diluent.

### *Ch Working Standard (20.0 µM)*

Dilute 1.00 mL of the Ch Stock Standard to 100.0 mL final volume with Standard Diluent.

### *ACh/Ch Test Mixture (10.0 µM each)*

Combine 10.0 mL of the ACh Working Standard with 10.0 mL of the Ch Working Standard.

**Figure 1-3.** 200 pmole injection of ACh and Ch using 10.0  $\mu\text{M}$  Test Mixture and Primary Mobile Phase recipe.

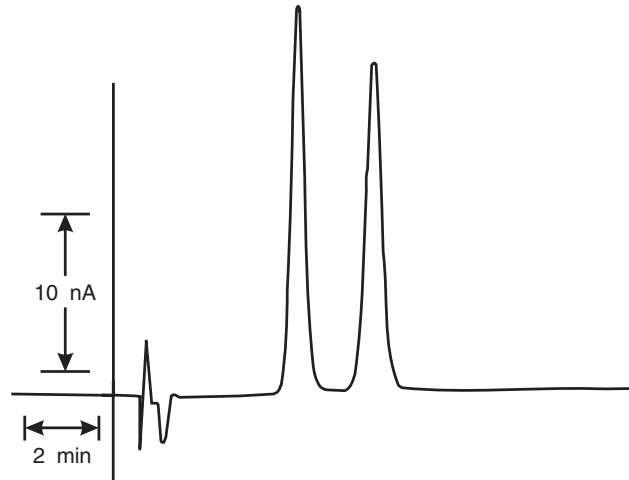

## 1.8 Fine Tuning the Separation

The BAS Acetylcholine/Choline analytical column supplied in this kit utilizes a polymeric, non-silica support with excellent stability in the pH 2-12 range. This proprietary packing material needs no ion pair agent for resolving ACh and Ch; it will equilibrate extremely quickly (<10 min) with any of the changes recommended here.

The variables which readily influence the separation are:

- type and concentration of cations in the mobile phase
- mobile phase ionic strength

**Flowrate.** A new IMER is overloaded (saturated) with respect to enzyme(s), so a flow rate of 1 mL/min (normal) will still result in 100% conversion of ACh and Ch to H<sub>2</sub>O<sub>2</sub>. As the IMER ages, the enzymes denature and conversion efficiently drops but response is still proportional to the concentration of the analyte. Only detection limits suffer (i.e., they are not as low). However, lowering flowrates prolong the residence time of ACh and Ch in the IMER, resulting in increased conversion and greater response. The drawback is increased run times. Try lowering the flowrate by 0.2 mL/min increments until response does not increase. A flowrate below 0.5 mL/min is not very practical. The above is a good compromise until a new IMER arrives (see Column Temperature). Similar rationale applies to the microbore kit but at proportionally lower flow rates.

**Buffer Cation.** There is a pronounced difference in retention for K<sup>+</sup>, Na<sup>+</sup>, or Li<sup>+</sup> as the buffer cation. In one experiment, 3.4 mL of 85% H<sub>3</sub>PO<sub>4</sub> was diluted to 900 mL and either KOH, NaOH, or LiOH was used to raise the pH to 8.50. The solution thus differed only in the cation. The retention times (ACh/Ch) were: K<sup>+</sup> (3.3/3.9 min), Na<sup>+</sup> (4.5/5.6 min), and Li<sup>+</sup> (9.8/15.8 min).

**Column Temperature.** Raising the column temperature from ambient to 35-37°C has little effect on efficiency or enzyme turnover of a new IMER. However, a low efficiency (aged) IMER is positively responsive to this same temperature change, thus prolonging its effective lifetime. Temperatures > 40°C or < 0°C will permanently reduce the enzyme activity of the IMER and should be avoided. Temperature control will benefit chromatographic and detector stability.

**Resolution.** The greatest resolution is obtained at the lowest ionic strength and slowest flowrate.

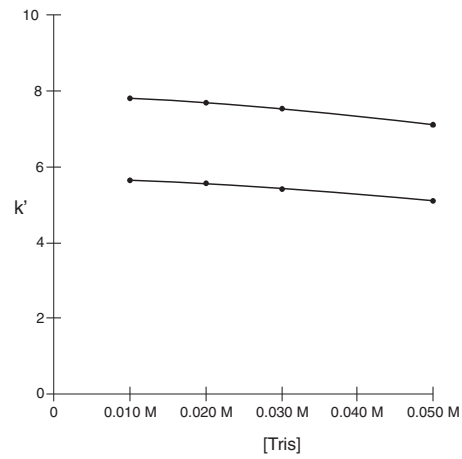
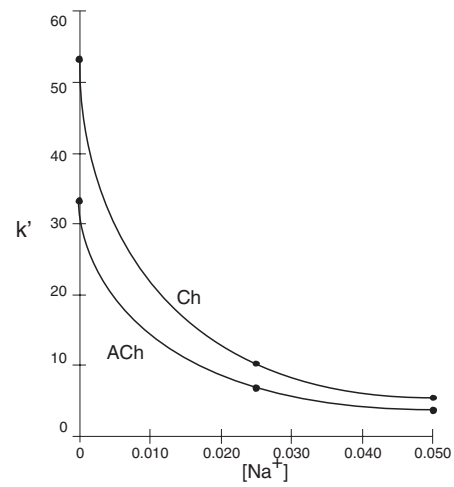
**Figure 1-4.** Dependence of retention time on [Tris] at fixed 0.05 M NaClO<sub>4</sub>, pH 8.50.**Figure 1-5.** Dependence of retention time on [Na<sup>+</sup>] at fixed 0.05 M tris, pH 8.50.

## 1.9 Application to Microdialysates

The concentrations of ACh and Ch may be determined *in vivo* by implantation of in-dwelling dialysis probes. The BAS “Rodent Residence” system for *in vivo* sampling of awake animals is shown in Figure 1-6. A BAS “Bee” Syringe pump (p/n MD-1001) perfuses the tissue at 0.5-5  $\mu\text{L}/\text{min}$ . A liquid switch permits the operator to select one of up to three perfusion fluids without interruption of the perfusate flow. Management of the fluid lines to and from the animal is carried out by a counterbalanced arm and liquid swivel.

Figure 1-7 shows the type of data obtainable from this system. A 3 mm dialysis probe implanted in rat caudate was perfused with Ringer’s solution and then Ringer’s containing 10  $\mu\text{M}$  neostigmine. The perfusion buffer was selected via the liquid switch. The absence of ACh in Figure 1-7B is due to the high acetylcholinesterase activity *in vivo*. ACh is hydrolyzed to Ch before it diffuses to the membrane of the probe. In contrast, the administration of the esterase inhibitor, neostigmine, to the perfused zone via the probe causes ACh to rise dramatically.

Complete details on the hardware and procedures for these experiments may be obtained from BAS.

**Figure 1-6.** BAS “Rodent Residence” awake animal sampling system (p/n MD-1575).

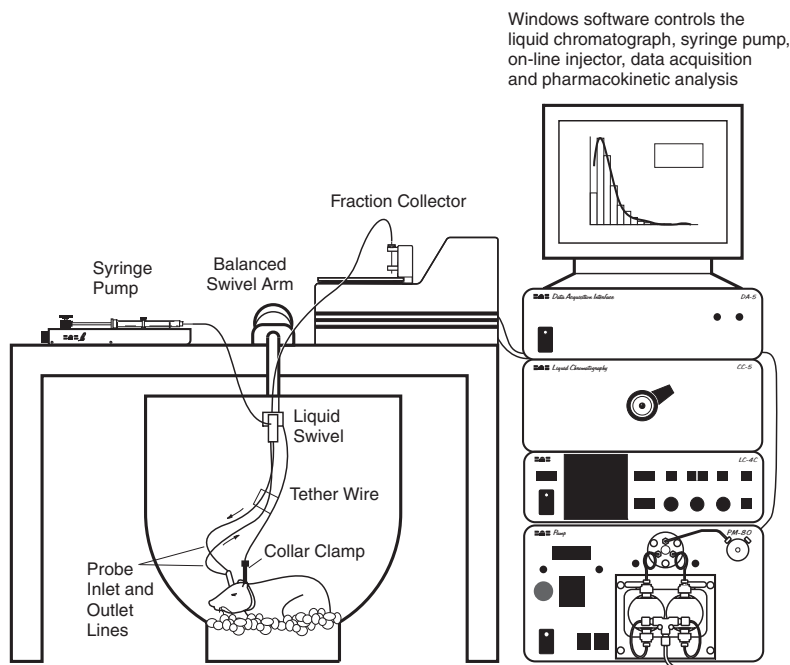



**Figure 1-7.** (A) 24.2 pmol each of ACh and Ch in standard. (B) Microdialysis perfusate, 17 min at 2  $\mu\text{L}/\text{min}$ , in rat caudate. Ringer's only. (C) Same as B, but Ringer's solution contained  $10^{-5}$  M neostigmine.

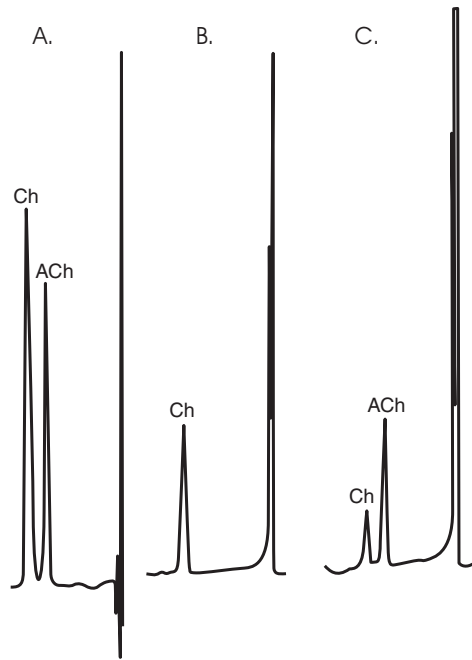

### Application to Brain Tissue Measurement

The recurring problem of high acetylcholinesterase activity *in vivo* obviates the use of conventional methods of animal sacrifice, such as decapitation. The focused microwave irradiation technique provides acceptable values; see W. B. Stavinoha, "Study of Brain Neurochemistry Utilizing Rapid Inactivation of Brain Enzymes by Heating with Microwave Irradiation," in *Microwave Fixation of Labile Metabolites*, C. L. Blank, W. B. Stavinoha and Y. Maruyama, eds., Pergamon Press, N.Y., 1983, pp 1-12. Localized heating denatures the esterase in situ; the brain tissue is then excised using conventional surgical techniques.

Some typical results are shown in Figure 1-8. Animals were killed by microwave irradiation (6 kW, 4 sec.) and the tissues were dissected and stored at -70°C until use. 50-200 mg tissues were homogenized in 1 mL of 0.02 M sodium phosphate, pH 5.3. Supernatants (15,000 x g, 15 min.) were injected directly. Chromatograms and procedure are courtesy of Dr. Dane Liston, Pfizer Central Research, Groton, CT.

**Figure 1-8.** Left: 20  $\mu$ L extract from rat cerebral cortex (approx. 4 mg tissue). Center: 10  $\mu$ L extract from rat caudate nucleus (approx. 1 mg tissue). Right: 10  $\mu$ L extract from improperly microwaved animal. Only choline is observed.

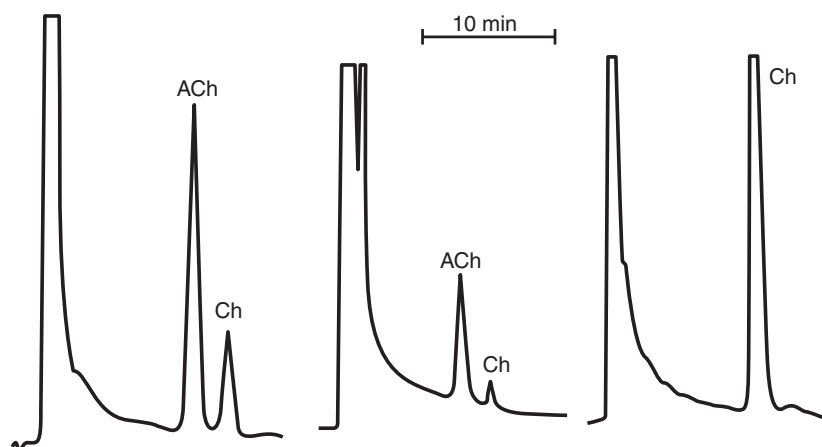

### 1.10 Effect of Inhibitors, Trapping Column

Oftentimes, the use of an acetylcholinesterase inhibitor is required. BAS has briefly studied the effects of two such inhibitors, neostigmine and physostigmine, on kit performance.

Solutions of neostigmine, a *reversible* AChE inhibitor, were made in Ringer's solution at 1.0 mM and 10.0  $\mu$ M concentrations. The immunity of the reactor towards this inhibitor was tested by concurrent injection of the neostigmine solutions and the 10.0  $\mu$ M ACh/Ch Test Mixture. The injections were timed such that neostigmine would co-elute with acetylcholine (Figure 1-9). The elution pattern of neostigmine was monitored at 254 nm with UV absorbance detection.

**Figure 1-9.** (A) Neostigmine, ACh, and Ch elution. ACh (pk. 1) is temporarily attenuated when injected neostigmine (1 mM) passes through reactor. Ch (pk. 2) is unaffected. (B) Same as A, but neostigmine is at 10  $\mu$ M. Shaded area represents neostigmine peak.

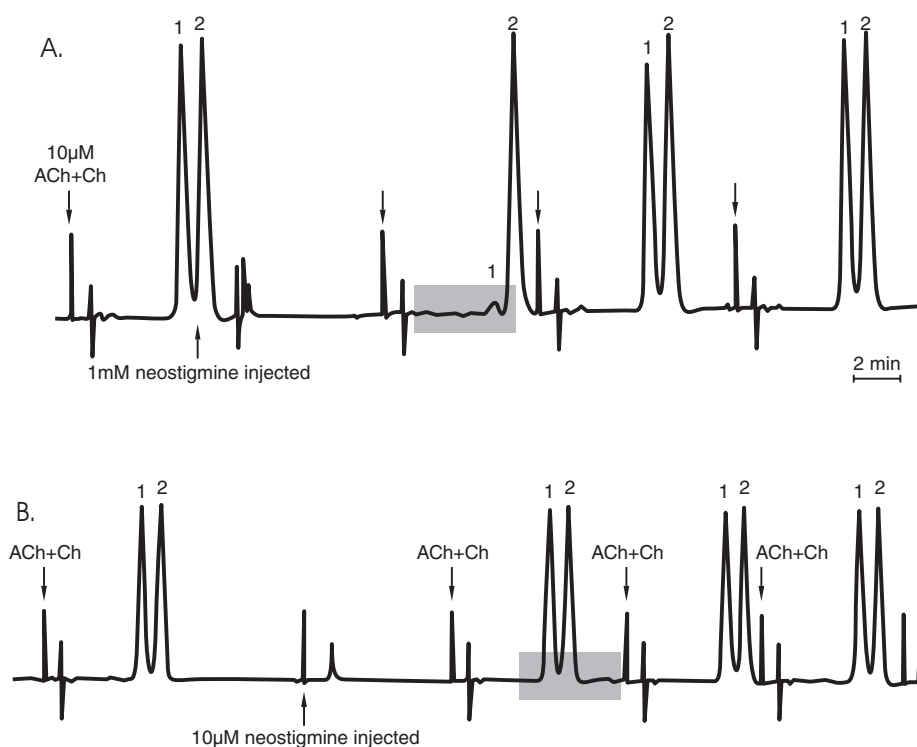

The reversibility of acetylcholinesterase inhibition is obvious in the 1.0 mM experiment, but this concentration is approximately 100-fold higher than what would be administered in a dialysis experiment. The 10  $\mu$ M runs demonstrate that the amount of AChE present is in sufficient excess for pharmacological experiments.

Physostigmine was tested differently. This compound, in a practical sense, is an *irreversible* cholinesterase inhibitor. The concern here is that each injection of sample containing physostigmine would "poison" the immobilized AChE until too little was left to effect the conversion of ACh to Ch. The problem would be cumulative. Since physostigmine is considerably more hydrophobic than ACh or Ch, a trapping column consisting of a

lipophilic polymer was placed at the head of the analytical column. See Figure 1-10. Both ACh and Ch would pass on through the trapping column unretained, while physostigmine would be stopped. The retention of physostigmine would be maximized under 100% aqueous conditions.

Thirty-two injections of 200 pmoles physostigmine were made during a 22 hour period; these were intermingled with periodic injections of the 10  $\mu$ M ACh/Ch Test Mixture. The ratio of ACh to Ch peak heights was calculated. The ratio dropped insignificantly, approximately 1%. This result implies that either:

- a. the physostigmine was retained on the trapping column, or
- b. the reactor is still adequately "staffed" with reserve enzyme, in spite of possible inhibitor leachate from the trapping column.

The trapping column can be washed out with water, methanol, water, and then mobile phase on a daily basis, by using a 5 mL hand held syringe and miscellaneous plumbing adapters. This takes all of 5 minutes to accomplish. The trapping column (MF-6262 for a pkg. of 3) and two pieces of cartridge column hardware (MF-6211 and MF-6010) are available separately from BAS.

---

**Figure 1-10.** Optional components for physostigmine experiment.

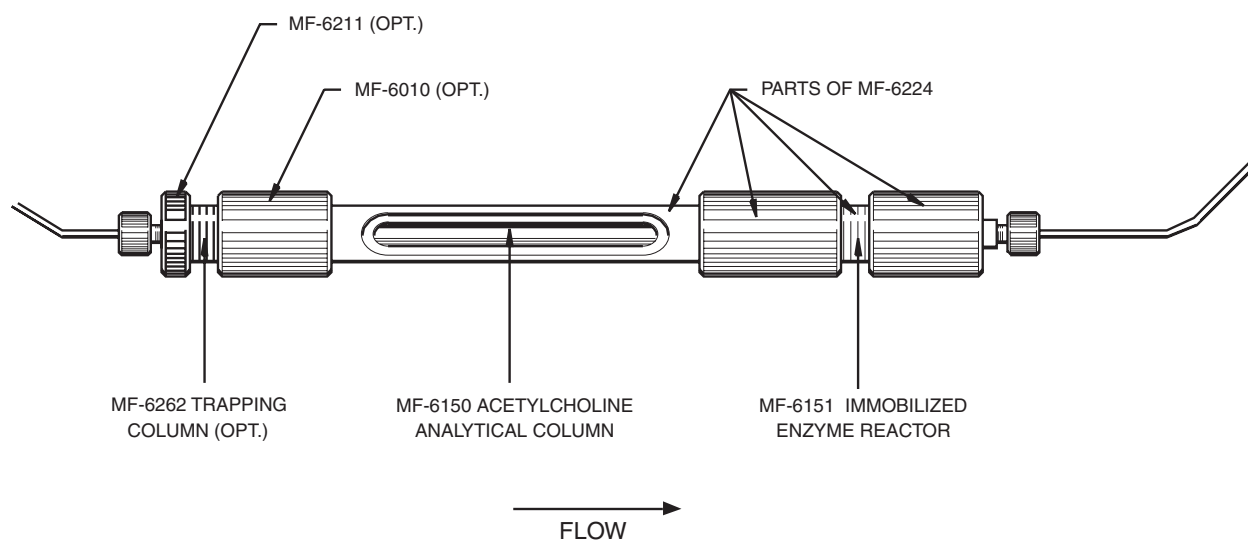

Using inhibitors with this kit has not been thoroughly explored. You should be cognizant of the potential problems.

### Reproducibility

Replicate injections of the 10  $\mu\text{M}$  ACh/Ch Test mixture were made at 7 min intervals.  
Reproducibility was excellent.

**Figure 1-11.** Serial injections of ACh and Ch (200 pmoles) using the kit at 1.0 mL/min, 35  $^{\circ}\text{C}$ , and 0.05 M sodium phosphate buffer (pH 8.50).

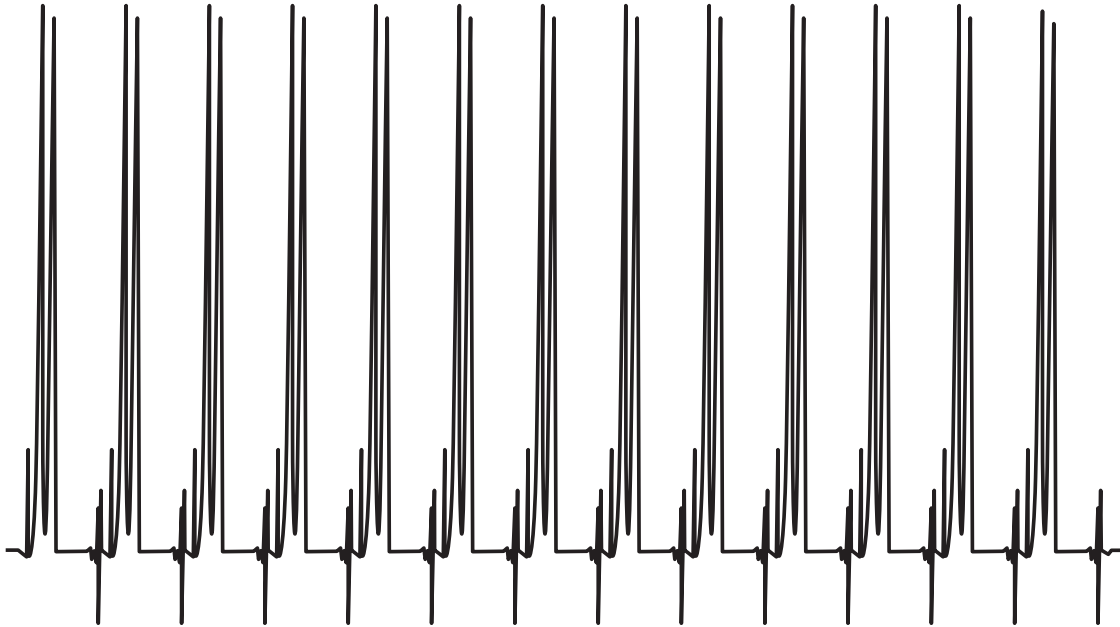

### 1.11 Determining Only Acetylcholine or Choline

Two tools augment the capability of the BAS Acetylcholine/Choline Kit. Both are IMERs which can be used in conjunction with the existing kit to increase the selectivity of the assay for ACh or Ch. One IMER makes use of choline oxidase alone, while the other combines ChOx and catalase as the covalently bonded enzymes. Using these in the proper chromatographic flow sequence allows for the quantitation of ACh only or Ch only.

Placing a precolumn ChOx IMER in the flow sequence has the effect of removing Ch (Figure 1-12A). The void response is greatly increased due to the precolumn's conversion of Ch to  $H_2O_2$ .  $H_2O_2$  is not retained on the analytical column and appears at the system's void volume. Using this same IMER as the post column reactor allows for the quantitation of Ch only (Figure 1-12B). When used as the precolumn, the ChOx/Catalase combination IMER erases Ch completely and significantly reduces the void response due to the Ch conversion; this improvement is due to digestion of the  $H_2O_2$  by catalase (Figure 1-12C).

**Figure 1-12.** Chromatographic Flow Sequence. MF-6150 ACh/Ch Analytical Column; MF-6151 ACh/Ch IMER; MF-6149 ChOx IMER; MF-6153 ChOx/Catalase IMER.

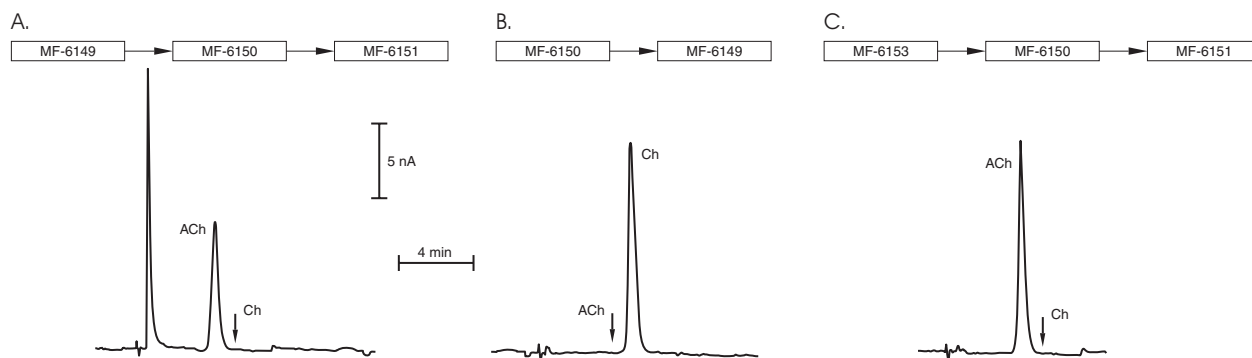

The proficiency of this precolumn can be seen in the examples shown in Figure 1-13. A mixture of Ch and ACh in a ratio of 100:1 was injected without the precolumn in place (Figure 1-13A). As can be seen, the ChOx/Catalase IMER completely removes the Ch response enabling the discrete quantitation of ACh without any possible interference from higher concentrations of Ch.

**Figure 1-13.** Chromatograms showing injections without MF-6153 precolumn (A) and with precolumn (B).

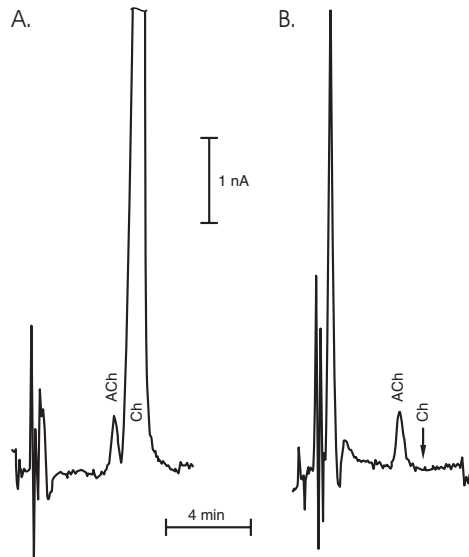

**Figure 1-14.** Arrangement of columns for experiment of Figure 1-13.

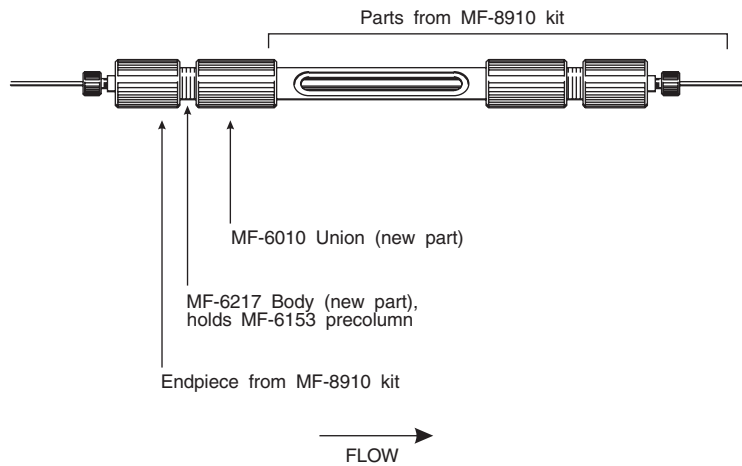

**1.12 Notes and Cautions**

1. Both the IMER(s) and analytical column should not remain on the LC system in stagnant mobile phase at room temperature. Keep the flow at 0.1 mL/min when not in active use, or store the columns in some fresh mobile phase at 4°C.
2. If the system will not be in use on a daily basis, return both the IMER and analytical column to storage at 4°C. Immerse both of these in freshly made mobile phase containing ProClin in the shipping tubes provided. For the recipe, refer to page 6. If ProClin is not present or available, add 2 drops of toluene to each tube for anti-microbial control. You should clean the shipping tubes with detergent/water and rinse thoroughly between uses.
3. Enzyme activity is a function of use. The 60 units each of choline oxidase and acetylcholinesterase is more than sufficient to insure complete conversion of the substrates to H<sub>2</sub>O<sub>2</sub>. Due to this excess loading, you will not notice a lapse in conversion efficiency until the number of units drops below a certain value, even though some activity has been lost each day of use.
4. Bacterial contamination of the system is a major hindrance to the proper function of this kit. Don't underestimate this aspect of peroxide detection. The problem is due to the catalase produced by bacteria:



Turnover is so high that virtually all peroxide is scavenged.

5. A lack of method sensitivity can be attributed to several causes. These are:
  - a. Negligible enzyme activity remaining in the reactor
  - b. Irreversible inhibition of the enzymes (organophosphates, etc.)
  - c. Bacteria
  - d. *In vivo* acetylcholinesterase activity - samples only exhibit Ch.
  - e. Passivation of platinum electrode or shift of reference electrode potential.
  - f. Bacteria decomposition of choline - samples only show ACh.
  - e. No oxygen in the mobile phase - choline oxidase requires oxygen for function.

The best way to determine the cause is to compare the system's response to stoichiometrically-related equivalents of ACh, Ch, and H<sub>2</sub>O<sub>2</sub>. Make up a 40 μM H<sub>2</sub>O<sub>2</sub> solution in the Standards Diluent.\* Due to the stoichiometry of Figure 1-1, a given volume of this solution and the same volume of 20 μM ACh and 20 μM Ch working standard solutions should all yield the same peak area.

*\*Use 30% reagent grade H<sub>2</sub>O<sub>2</sub> in H<sub>2</sub>O to make this reagent. Dilute as follows:*

1. Dilute 1.0 mL of 30% H<sub>2</sub>O<sub>2</sub> to 100 mL with H<sub>2</sub>O (conc = 97.9 mM).
2. Dilute 1.0 mL of 97.9 mM solution to 100 mL with H<sub>2</sub>O (conc = 979 μM).
3. Dilute 4.1 mL of 979 μM solution to 100 mL with the Standards Diluent (conc = 40 μM).



**Debug the system as follows:**

- A. Remove the analytical column and the IMER. Connect a plastic 1/16" tube from the injector to the detector.

You will be measuring areas. A simple, convenient way to do this is to use the highest chart speed on a strip chart recorder and then "cut-and-weigh" the peaks as a measure of area.

Inject the peroxide solution and measure the peak area. Also inject the Standards Diluent and subtract its area, if not negligible. Let A = net area due to peroxide.

Now reinstall the analytical and enzyme columns and make the injections again. Let B = net area. Calculate:

$$\% \text{ recovery} = \frac{B}{A} \times 100$$

The recovery should be  $100 \pm 10\%$ . *Low recovery of  $H_2O_2$  is most likely due to bacteria or catalase.*

- B. With both columns in-line, inject peroxide and then separately, ACh and Ch. Measure areas. Calculate:

$$\text{CONVERSION Ch} = \frac{\text{AREA Ch}}{\text{AREA H}_2\text{O}_2} \times 100$$

$$\text{CONVERSION ACh} = \frac{\text{AREA ACh}}{\text{AREA H}_2\text{O}_2} \times 100$$

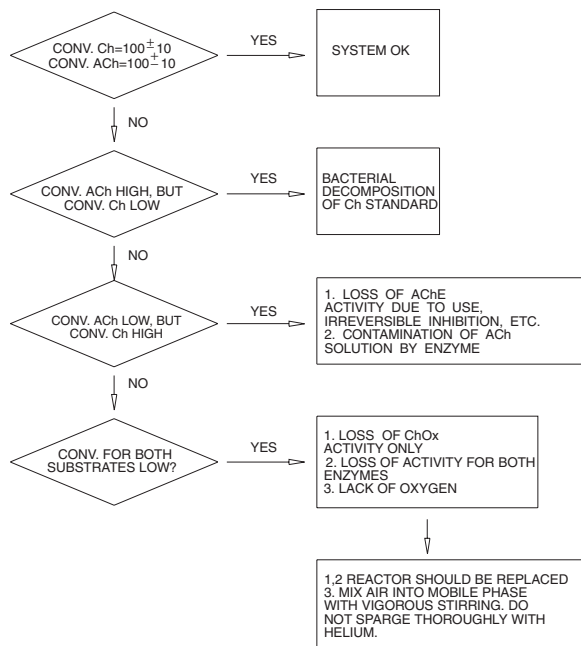

- An appropriate internal standard is acetylthiocholine, which elutes after Ch. This compound is available from Sigma in various salt forms. See Figure 1-15. This is not recommended in the microdialysis experiment since samples are being processed directly, and it may not even be necessary when dealing with brain homogenates.

**Figure 1-15.** Elution of acetylthiocholine (AcTCh), Ch, and ACh. Mobile phase: 50 mM sodium phosphate (pH 8.50), 1 mL/min, 35 °C.

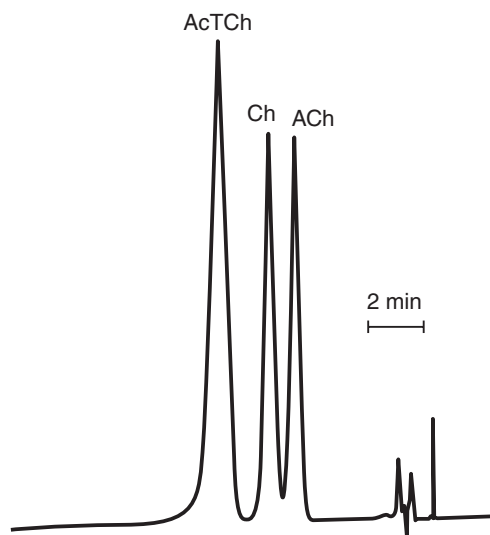

- The use of peak heights for quantitation, rather than areas, is advised for the best precision. Oftentimes this will allow you to increase elution speed, without sacrificing resolution, by using higher ionic strength mobile phases. For example, 3-4 minute elution times using 70-100 mM sodium phosphate buffer (pH 8.5) at 1.0 mL/min would be possible.
- Under some conditions, odd negative- and positive-going dips will occur. These are not enzyme-dependent. An example is shown in Figure 1-16 at high detector gain. These dips are most aggravating when you inject larger volumes of acidic homogenates or high ionic strength perfusion media.

The responsible processes are not yet clear, although titration of the sample with a base eventually eliminates the dip, as the pH of the titrated sample approaches the pH of the mobile phase.

One way to eliminate the problem is to neutralize most of the sample's acidity prior to injection. A partially effective strategy was to add a few  $\mu\text{L}$  of a concentrated  $\text{Na}_3\text{PO}_4$  solution (a base). As long as the final pH reached 8-8.5, the artifact was erased. But overtitration of the sample reversed the polarity of the dip and its magnitude increased. These experiments thus led to the preferred "Primary Mobile Phase" described on page 6. The Tris is a better buffer at pH 8.5 than the phosphate system; direct injection of acidic homogenates are thus more readily neutralized, with less baseline disturbance.

With the Tris system, it is also easier to bring up the sample pH to the mobile phase pH prior to injection. For example, a few  $\mu\text{L}$  of a concentrated Tris base solution (e.g., 1.5 M, pH 8.8) could be added to every PCA sample to bring up the pH to 8.5 just prior to injection, without serious dilution effects.

Usually these maneuvers are only necessary when working at high sensitivity.

**Figure 1-16.** Injection of 15  $\mu\text{L}$  dialysate from rat caudate nucleus. Perfusion medium: Ringer's + 10  $\mu\text{M}$  neostigmine. The baseline disturbance is circled. Mobile phase: 0.05 M sodium phosphate (pH 8.5); 35  $^{\circ}\text{C}$  temperature, and 1.0 mL/min flowrate.

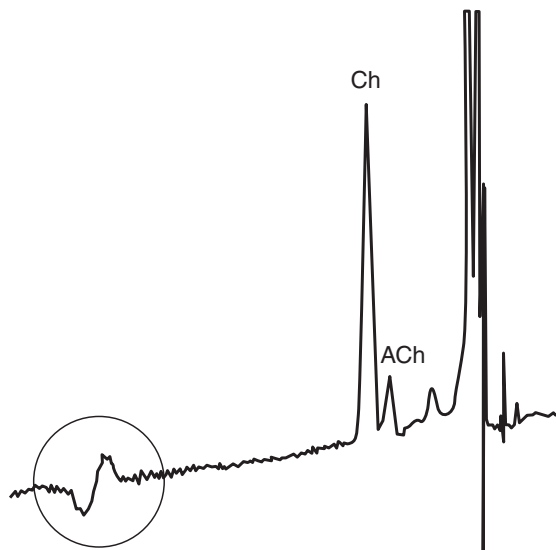

9. Neither the analytical column nor the IMER should be flushed with organic solvents. Solvents will denature the enzymes of the IMER, resulting in partial or complete loss of activity. The IMER can only be washed with fresh mobile phase. The analytical column can be washed with a high-salt mobile phase after removing the IMER (store at 4 $^{\circ}\text{C}$ ). Prepare one liter of mobile phase. Take out a 250 mL portion and make it 0.5 M with respect to NaCl. Pump this high-salt mobile phase through only the analytical column at 1 mL/min. After at least 200 mL have passed through the column, switch to the usual mobile phase to wash out the NaCl and equilibrate the column (> 60 mL). The IMER can now be reattached.
10. On the use of ProClin: A paper by Tyrefors and Carlsson in the *Journal of Chromatography*, 502 (1990) 337-350, suggests the use of Kathon CG (BAS ProClin), a cosmetic grade preservative, as an effective agent for preventing bacterial growth. We have evaluated this over a limited time period and believe it to be useful. A 1% solution in water is now included in your kit along with the appropriate Material Safety Data Sheet. We are supplying this bacteriocide in diluted form since the original concentration is corrosive and capable of causing chemical burns. At 1:100, this dilution is classified as a "skin sensitizer."

Mix 5 mL of 1% ProClin (as supplied) with 1 L of mobile phase. Larger concentrations are no more effective and may cause cloudiness or precipitation in the mobile phase.

We find that a 1 L batch of mobile phase, suitably covered from dust, is good for at least 1 week. You may recycle the mobile phase if the tube from the detector back to the mobile phase vessel is free of bacteria.

ProClin has an interesting effect on choline linearity. We have noticed with older analytical columns that ACh will be linear, but Ch will present a negative deviation for the lowest amounts injected. The choline peak can ultimately disappear. Apparently, at low enough concentrations, some choline is “lost” on the analytical column. With ProClin in the mobile phase at a 5:100,000 dilution, this effect is reversed within a few column volumes and linearity is completely restored.

11. Although a pump's performance is usually optimized at a predetermined pressure it will perform fine over a wide pressure range. In fact, this characteristic will probably be noticeable only under demanding or sensitive detector conditions. However, to accommodate this characteristic the Conventional Cartridge Column version of the kit includes a length of PEEK tubing, which can be used to increase the total system pressure. The tubing is placed between the pump and injector. The ID of the tubing is 64  $\mu\text{m}$  and at a flow rate of 1 mL/min each cm length will add about 80 psi to the total pressure. The tubing can be cut to the required length (back pressure) with a razor blade.

For example, the BAS PM-80 exhibits optimum performance at  $3000 \pm 200$  psi. The back pressure due to the analytical column and IMER of the Conventional kit at 1 mL/min is 1200-1400 psi. To optimize the PM-80 performance, we must increase the total system pressure by 1600-1800 psi. Since the tubing produces  $\approx 80$  psi/cm, a 22 cm length must be placed in-line between the purge valve and the injector (other tubing and filters can still be in-line). Make the tubing a little longer than calculated, since you can always cut it shorter! Use PEEK nuts and ferrules to connect the tubing to the system. Be careful not to overtighten these connections. An overtightened connection can occlude this small ID tubing.

The microbore columns produce a back pressure of 2250-2400 psi at a flow rate of 130  $\mu\text{L}/\text{min}$ , so additional back pressure is not usually required.

## Section 2. UniJet Microbore ACh/Ch Kit

2.1 Inventory of Microbore ACh/Ch Kit (MF-8908)	Qty	BAS p/n	Description
	1	CF-1042	Choline chloride standard
	1	CF-1043	Acetylcholine chloride standard
	1	CF-2150	1% ProClin reagent
	1	MF-9053	Instruction Manual for ACh/Ch Assay Kit
	1	MR-9231	Guide for use: BAS UniJet Microbore Column
	1	MR-4416	PEEK nut and ferrule
	1	MF-8904	Microbore ACh/Ch analytical column
	1	MF-8903	Microbore ACh/Ch IMER, 2/pkg.
	1	MR-4403	PEEK Union and 2 fittings
	1	MW-4527	Tube 0.03 x 10 cm
	1	MW-4526	Tube 0.03 x 15 cm
	1	MW-6031	Flow splitter accessory

### 2.2 Optional Accessories IMERs and guard columns

MF-8907 microbore choline oxidase/catalase IMER (55 x 1 mm)

MF-8906 microbore choline oxidase IMER (55 x 1 mm)

MF-8935 microbore ACh/Ch guard column (14 x 1 mm)

#### Wired Enzyme Electrode Kit: (see Appendix I)

### 2.3 Installation of the ACh/Ch Microbore Column and IMERs

The UniJet microbore ACh/Ch column is fabricated from a 1/16 in. OD, 1 mm ID, 530 mm long stainless steel tube. The UniJet microbore ACh/Ch IMER is fabricated from the same tubing, but it is 50 mm long. The columns can be directly connected to the injector valve and the electrochemical detector cell without the use of extra tubing. NOTE: The use of stainless steel ferrules must be avoided as the swaging process will damage the columns. The procedure is as follows:

1. If a guard column is used, it is directly connected to the UniJet microbore Injection Valve. A PEEK ferrule is placed on the guard column. The two are inserted into port 3 and swaged with a UniNut (Figure 2-5, page 29). Bottom the guard column into the port by pushing on it with a piece of standard 1/16 in. OD tubing while tightening the UniNut. This will ensure a zero dead volume connection. Place a PEEK nut and ferrule over the top of the ACh/Ch analytical column and insert it into the UniNut, bottoming it on the guard column. Keep pushing on the analytical column with firm pressure as you finger tighten the nut; add a 1/4 turn using a wrench. Do not overtighten. If it does not leak when the pump is turned on, the nut is tight enough.

2. If a guard column is not used, directly insert the analytical ACh/Ch column into port 3 of the injector valve. Be sure the analytical column bottoms out, and swage the column as above using a PEEK nut and ferrule.
3. Connect a postcolumn IMER to the bottom of the analytical column using a PEEK union and PEEK nuts and ferrules. The bottom of the IMER is directly connected to the inlet of the auxiliary electrode.
4. If a precolumn IMER is used, insert it into port 3 of the injector valve and swage as above using a PEEK nut and ferrule. Connect the precolumn IMER to the analytical column using a PEEK union and PEEK nuts and ferrules. Connect the postcolumn IMER to the analytical column and cell as above. Be sure to keep the IMERs in their respective labeled vials when not in use; their small length precludes the use of attached labels.

**Figure 2-1.** UniJet microbore ACh/Ch analytical column and IMER.

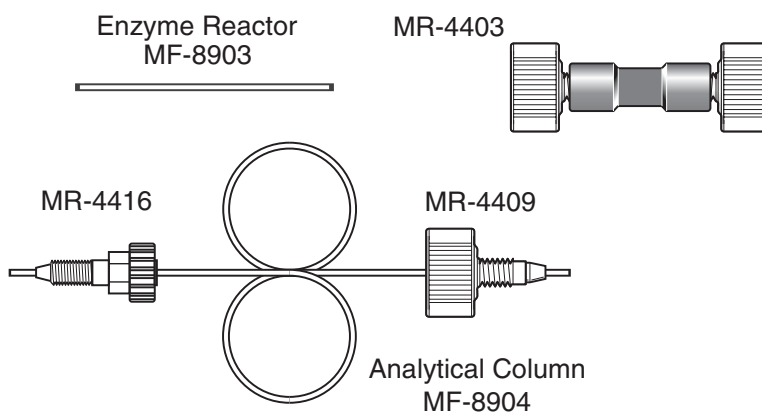

## 2.4 Chromatographic System Conditions

Flow rate: 130  $\mu\text{L}/\text{min}$   
Pump: BAS PM-80  
Column temperature: ambient  
Detector: BAS LC-4C  
Electrode: platinum  
Potential: +500 mV vs. Ag/AgCl  
Mobile phases: see below

*Primary UniJet mobile phase:* Dissolve 6.9 g  $\text{NaH}_2\text{PO}_4 \cdot \text{H}_2\text{O}$ , 0.18 g  $\text{Na}_2$  EDTA and 5 mL ProClin in 995 mL LC-grade water. Adjust pH to  $8.50 \pm 0.05$  with 6 N NaOH. Filter through a 0.2  $\mu\text{m}$  membrane. Expiration date is one week later.

*Alternate UniJet mobile phase:* Dissolve 4.6 g ammonium acetate, 0.18 g Na<sub>2</sub> EDTA, 1.2 g Trizma<sup>®</sup> base, and 5 mL ProClin in 995 mL LC-grade water. Adjust pH to  $8.50 \pm 0.05$  with acetic acid. Filter through a 0.2  $\mu\text{m}$  membrane. Recommended flow rate with this mobile phase is 100  $\mu\text{L}/\text{min}$ . The longer elution time of this recipe allows separation of the internal standard acetylthiocholine. Expiration date is one week later.

*Note:* This mobile phase will result in a higher background current due to the Trizma<sup>®</sup> base.

*Note:* Flow can be controlled directly by a pump that can deliver 100 or 130  $\mu\text{L}/\text{min}$ , or by using the FlowSplitter (see enclosed instructions).

**Figure 2-2.** UniJet microbore ACh/Ch analytical column and IMER.

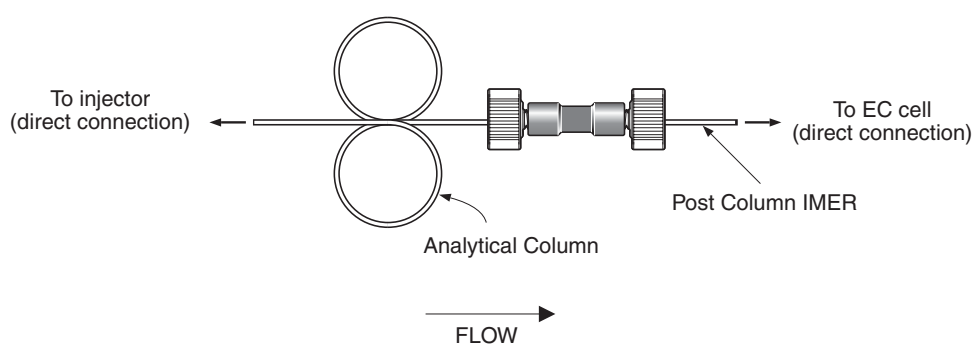

**Figure 2-3.** Acetylcholine and choline in rat striatum microdialysate. A and B) Dialysate collected during perfusion of Ringer's solution containing neostigmine, an acetylcholinesterase inhibitor. C) 1 pmole standards. Primary mobile phase used.

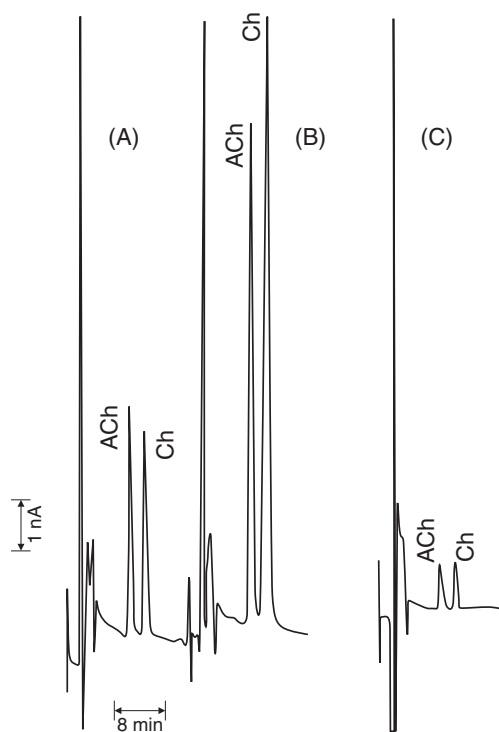

**Figure 2-4.** Separation of acetylcholine, choline, and internal standard (acetylthiocholine). Alternate mobile phase used.

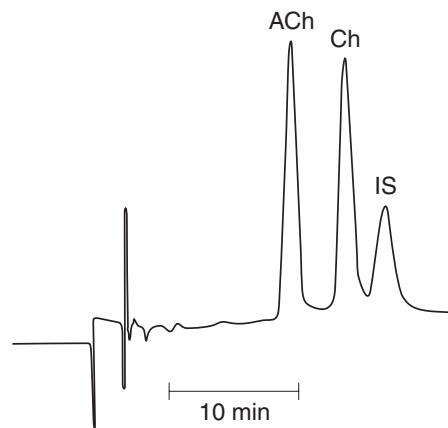



## 2.5 Use of a Guard Column (BAS p/n MF-8935)

In many cases, analytical columns can be clogged due to particles in the sample or debris thrown off from pump and injector seals. A UniJet guard column (1 x 14 mm) will protect the analytical column and does not reduce separation efficiency. Figure 2-6 is a comparison with and without a guard column.

**Figure 2-5.** UniJet guard column installation procedures: (A) insert the guard column into a PEEK ferrule and connect to the special UniNut; (B) mount the nut and guard column onto an injector valve; (C) Connect a UniJet analytical column to another UniNut and ferrule and; D) insert into the first UniNut which is attached to the injector valve.

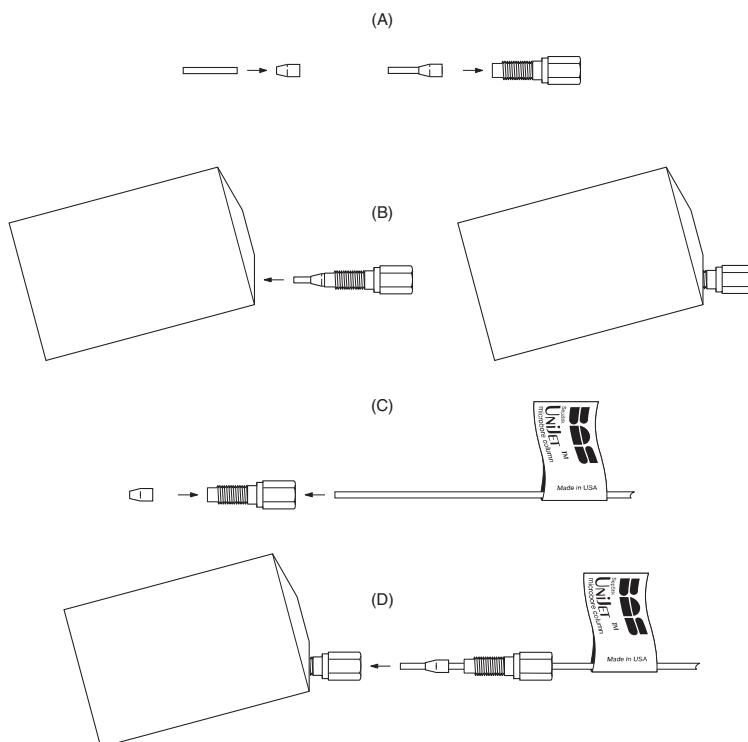

**Figure 2-6.** Comparison of performance with and without using a UniJet ACh/Ch guard column. The same standard solution of acetylcholine (ACh) and choline (Ch) was injected. A) UniJet ACh/Ch analytical column only (ACh/Ch, 530 x 1.0 mm). B) With an ACh/Ch guard column (14 x 1.0 mm).

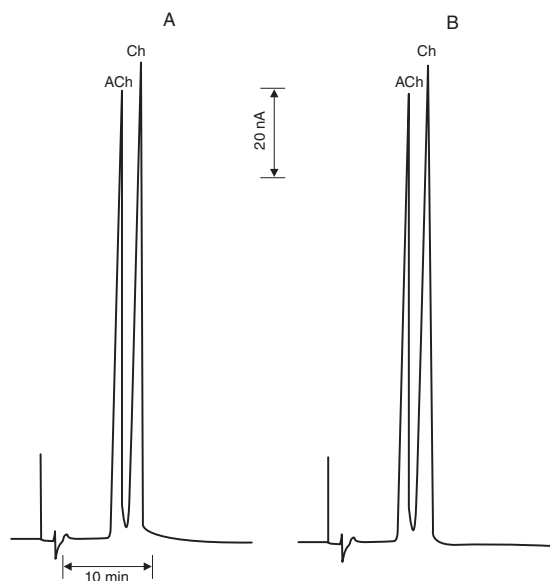

## 2.6 Determining Only Acetylcholine or Choline

In many cases, only the ACh peak is of interest; however, a large Ch peak may interfere. The Ch peak can be excluded from the chromatogram by placing a ChOx/catalase IMER (BAS p/n MF-8907) or ChOx IMER (MF-8906) prior to the analytical column. Both IMERs will remove the choline peak. When the ChOx/catalase IMER is used, the void peak can be minimized. The ChOx oxidizes the choline to betaine and  $H_2O_2$  and the catalase catalyzes the decomposition of  $H_2O_2$  to  $H_2O$  and  $O_2$  prior to the analytical column. The void response is thus reduced compared to the choline oxidase IMER which still exhibits a response to the  $H_2O_2$  (see Figure 2-7).

Using the ChOx IMER as the only postcolumn reactor allows for the quantitation of Ch only.

**Figure 2-7.** Microbore Chromatographic Flow Sequence. MF-8904 ACh/Ch microbore analytical column; MF-8907 ChOx/Catalase IMER; MF-8903 ACh/Ch IMER; MF-8906 ChOx IMER.

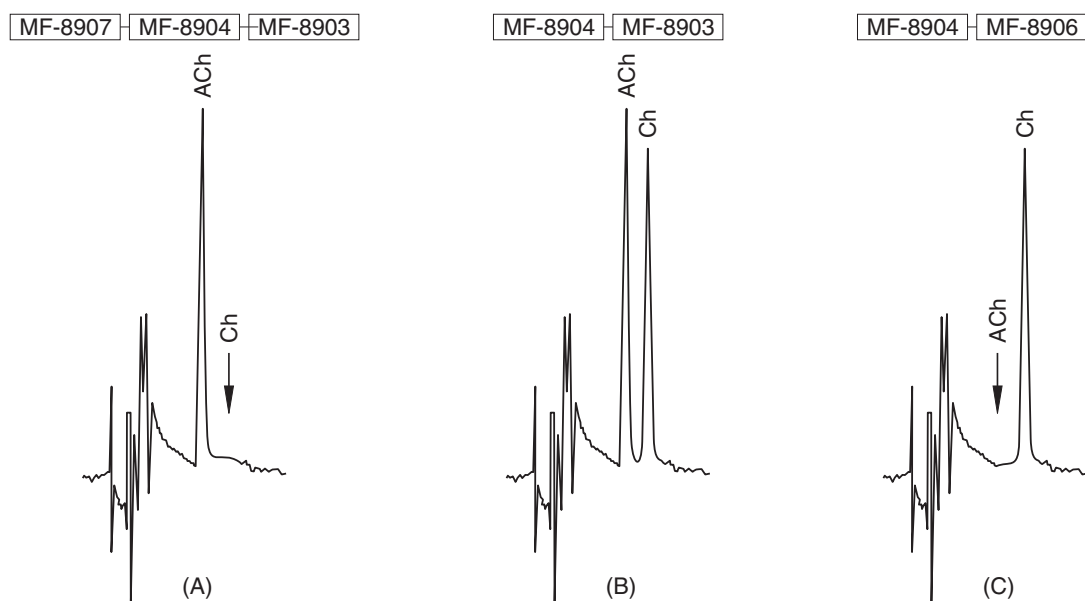

**2.7 Care of the Analytical Column and IMERs**

1. All IMERs should be stored at 4°C when not in use.
2. After use, flush the analytical column and IMERs using a 0.005% ProClin solution (mix 5 mL of 1% ProClin with 995 mL LC-grade water) at a flow rate of 130  $\mu$ L/min for 20 minutes. Put each IMER in its plastic vial, add several drops of 0.005% ProClin solution and cap the vials to keep the IMERs wet. Store at 4°C.
3. To store the analytical column, put a cap on each end of the flushed column. Store at 4°C or at room temperature.
4. The flow through the analytical column can be in either direction. If high back pressure is built up for some reason, remove the postcolumn IMER, reverse the analytical column, and run the flow in the reverse direction. Replace the IMER.
5. Never run solutions containing organic solvents through the analytical column or the IMERs.
6. If the analytical column becomes contaminated and peak tailing is observed, remove the IMERs and flush the analytical column with fresh mobile phase made 0.5 M with respect to NaCl. Wash at 130  $\mu$ L/min overnight or at least for 3 hours. After this treatment, run mobile phase through the column for at least 15 minutes to wash out the NaCl. Replace the IMERs.
7. As with all microbore columns, care must be taken to exclude all particulate from the columns. See the "Guide For Use: BAS UniJet Microbore Columns" for details.

## **Appendix I. Introduction to the Peroxidase Electrode**

ACh and Ch are usually determined using a platinum electrode. The H<sub>2</sub>O<sub>2</sub> generated in the post column IMER is readily oxidized at the platinum electrode.

The peroxidase electrode is an enzyme coated glassy carbon electrode. A redox polymer film containing peroxidase is coated on the surface. This redox polymer, derived of poly(vinylpyridine) partly complexed to [Os(bpy)<sub>2</sub>Cl]<sup>2+/3+</sup> redox center, electrically "wires" peroxidase to the electrode. The wired peroxidase electrode can be operated at +100 mV (vs. Ag/AgCl) for the reduction of H<sub>2</sub>O<sub>2</sub> produced from IMERs. Such an electrode is frequently referred to as a biosensor.

Compared with the Pt electrode, the wired peroxidase electrode exhibits an improved detection limit (10 fmoles) and operational stability. When the peroxidase enzyme electrode is coupled to a microbore LC-ACh/Ch IMER system, the initial stabilization of the background current is significantly faster than for the conventional Pt electrode; usually 30 minutes.

The wired peroxidase electrode is not included in the Conventional or Microbore ACh/Ch Assay Kits.

### **References**

Applications of "Wired" Peroxidase Electrode for Peroxide Determination in Liquid Chromatography Coupled to Oxidase Immobilized Enzyme Reactors. *Anal. Chem.*, 1995, 67, 1326-1331, L. Yang, E. Janle, T. Huang, J. Gitzen, P.T. Kissinger, M. Vreeke and A. Heller.

Detection of basal acetylcholine in rat brain microdialysate. *J. Chromatogr. B*, 1995, 670, 323-327, T. Huang, L. Yang, J. Gitzen, P.T. Kissinger, M. Vreeke and A. Heller.

### **Ordering Information**

MF-2095 Peroxidase Electrode Kit for Cross-Flow Electrodes

MF-2098 Peroxidase Electrode Kit for UniJet Electrodes